

Isolator & Circulator Basics

by MECA Electronics, Inc.

An RF isolator is a two-port ferromagnetic passive device which is used to protect other RF components from excessive signal reflection. Isolators are commonplace in laboratory applications to separate a device under test (DUT) from sensitive signal sources. An RF circulator is a three-port ferromagnetic passive device used to control the direction of signal flow in a circuit and is a very effective, low-cost alternative to expensive cavity duplexers in base station and in-building mesh networks. Examples of both applications will be covered in this article.

To understand how these components control the signal flow, think of a cup of water into which you place a spoon and stir in a clockwise motion. If you sprinkle some pepper into the cup and continue to stir, you will notice that the pepper easily follows the circular motion of the water. You can also see that it would be impossible for the pepper to move in a counterclockwise direction because the water motion is just too strong. The interaction of the magnetic field to the ferrite material inside isolators and circulators create magnetic fields similar to the water flow in the cup. The rotary field is very strong and will cause any RF/microwave signals in the frequency band of interest at one port to follow the magnetic flow to the adjacent port and not in the opposite direction.

Figure 1 shows the schematics for a circulator and an isolator. Notice how an isolator is a circulator with the third port terminated. The arrows represent the direction of the magnetic fields and the signal when applied to any port of these devices. Example: If a signal is placed at port A, and port B is well matched, the signal will exit at port B with very little loss (typically 0.4 dB). If there is a mismatch at port B, the reflected signal

from port B will be directed to port C. As you will note, it makes no difference which port is the input of the circulator because the relationship at the outputs remains the same as these devices are electrically and mechanically symmetrical.

Isolation

An important consideration when specifying an isolator or circulator is to ensure the device has adequate isolation for your given application. Isolation is a unit of measure (in dB) that states the separation of signal levels on adjacent ports of a device. The greater the isolation value, the less interference from a signal on one port relative to an adjacent port. The amount of isolation is directly affected by the VSWR presented at port 3 of the isolator. If the match on port 3 is poor, you can expect isolation below 10 dB, but if the match is improved to 1.10:1 by using a good termination device in the circuit, then the isolation would improve to over 20 dB. In some applications greater isolation is required (30 to 40 dB). In these situations a dual junction isolator is used, which will be covered later.

Insertion Loss

Another important consideration when specifying a circulator or isolator is to ensure the device has minimal insertion loss when inserted in a transmission path. Generally, the insertion loss of a circulator or isolator (or any microwave device for that matter) becomes more significant at higher frequency, namely because loss increases with frequency and higher frequency power sources are considerably more expensive. Accordingly, the criteria of low insertion loss will prevent precious power from being wasted.

Common Applications

As described earlier, a common application for a circulator is

as an inexpensive duplexer (a device enabling a transmitter and receiver to sharing one antenna). Figure 2 shows that when the transmitter sends a signal, the output goes directly to the antenna port and is isolated from the receiver. Good isolation is key to ensure that a high-power transmitter output signal does not get back to the receiver front end as is governed by the return loss of the antenna. In this configuration,

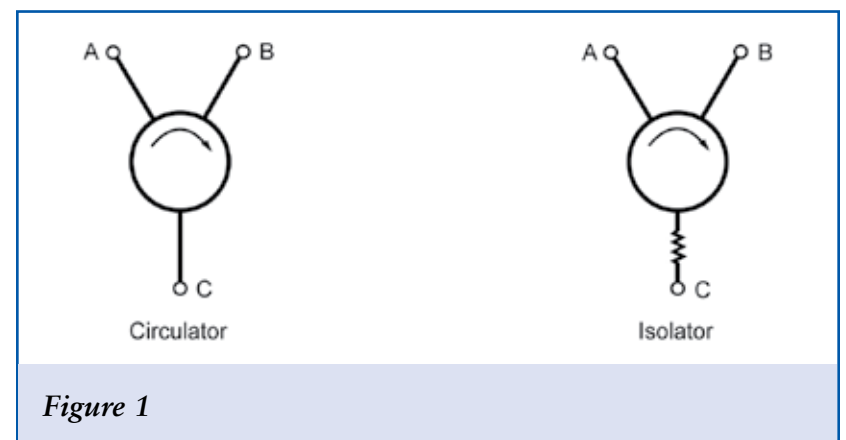

Figure 1

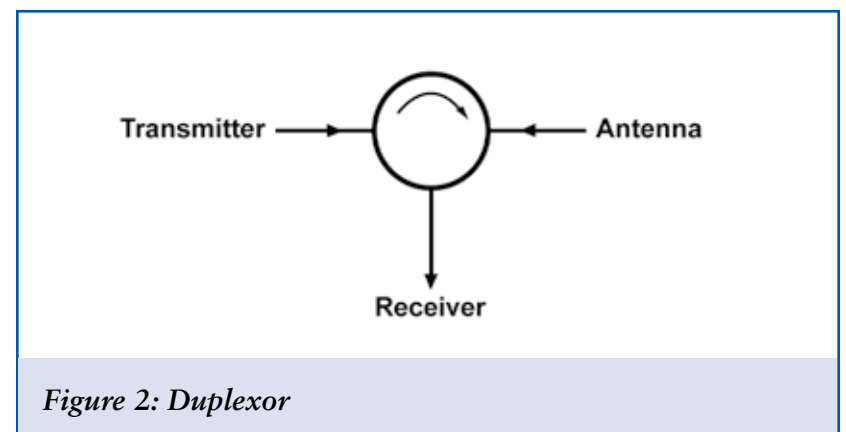

Figure 2: Duplexor

all signals from the antenna go straight to the receiver and not the transmitter because of the circular signal flow (remember the cup of water).

Figure 3 illustrates the most common application for an isolator. The isolator is placed in the measurement path of a test bench between a signal source and the device under test (DUT) so that any reflections caused by any mismatches will end up at the termination of the isolator and not back into the signal source. This example also clearly illustrates the need to be certain that the termination at the isolated port is sufficient to handle 100% of

the reflected power should the DUT be disconnected while the signal source is at full power. If the termination is damaged due to excessive power levels, the reflected signals will be directed back to the receiver because of the circular signal flow.

When greater isolation is required, a dual junction isolator is used as shown in Figure 4. A dual junction isolator is effectively two isolators in series but contained in a single package. Typical isolation performance can range from 40 to 50 dB with this type of design.

Power Ratings

MECA Electronics' single junc-



Isolators & Circulators



Dual & Single Junction Isolators meets IP67

tion isolators are designed with an internal 10W load capability. However, the recommended maximum power that our devices can sustain is 2W to allow for de-rating and heat transfer. Higher isolator power levels can be achieved utilizing our circulators with an external load which would make the limiting factor the ferrite material and not an internal resistor. As previously outlined, if the match on the terminated port is poor, you can expect isolation below 10 dB, but if the match is improved to 1.10:1 by using a good termination device in the circuit, then the isolation would improve to over 20 dB. MECA Electronics manufactures an extensive selection of high power, low loss RF loads.

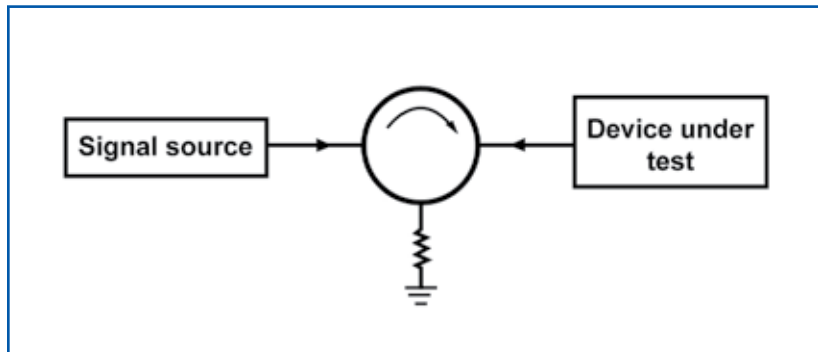

Figure 3

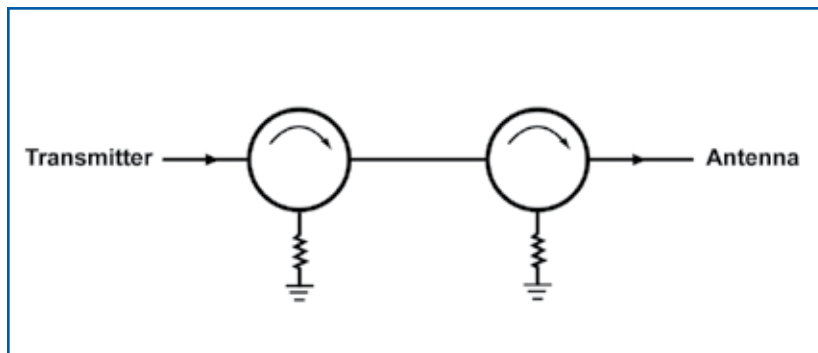

Figure 4: Dual Junction Isolator

Please consult with a MECA Electronics applications engineer to discuss your requirement and select the proper termination for your high power isolator.

MECA Electronics' dual junction isolators are designed with an internal 100W load capability. However, the recommended maximum power that our devices can sustain is 50W to allow for de-rating and heat transfer to an external heat sink. Higher isolator power levels can be achieved utilizing the proper heat sink.

Packaging

Isolators and circulators are available in various packaging options ranging from drop-in and surface mount to connectorized packaging. To address the need for outdoor and tower mounted requirements; MECA Electronics has introduced a

new line of single and dual junction isolators enclosed in an IP67 housing and suitable for outdoor long term use. The isolators are available in both cellular and PCS frequency bands; contact the factory for more details.

Special Handling & Storage

Isolators and circulators have magnets that produce strong fields to control signal flow. As is the case with any magnet, when placed in close proximity to another, the magnetic fields oppose one another, and over time, will weaken the strength of the magnets. This is called degaussing. A similar effect can be seen when stored in close proximity to ferrous metals. Special care should be taken when storing any circulator or isolator and MECA Electronics recommends that the devices should be separated by at least 3 inches from each other

& all ferrous surfaces to reduce degaussing effects.

MECA Electronics offers over 28 models of circulators and isolators in both N & SMA-Female connectors with average power ratings from 2 - 250 Watts. The most "popular" frequency bands between 0.7 - 18.0 GHz are readily available and can ship from STOCK to 4 weeks after receipt of your order.

MECA Electronics, Inc.

Since 1961, MECA Electronics has designed and manufactured an extensive line of RF/Microwave components with industry leading performance including Fixed Attenuators, Directional & Hybrid Couplers, Isolators/Circulators, Power Divider/Combiners, RF Loads/Terminations, Integrated Assemblies, Diplexers, Adapters, Cable Assemblies, DC Blocks & Bias Tees. MECA Electronics serves all areas of the RF and Microwave industries including world class network providers and supporting supply chain infrastructure, and has long been the "backbone" of high performance wired and air-interfaced networks such as in-building applications, satellite communications, radar, radio communications, telemetry applications, mobile radio, aviation & air traffic communications.

For more information visit www.e-MECA.com or call 973-625-0661.

MECA Electronics, Inc. 459 East Main St., Denville, NJ 07834.

MECA ELECTRONICS, INC.